

demmel products gmbh

Email: sales@demmel.com www.demmel.com

SPECIFICATION

DCD-MX101

For Customer's Acceptance:

Approved By	Comment		
PREPARED	CHECKED	VERIFIED BY QA DEPT	VERIFIED BY R&D DEPT

REVISION HISTORY

REV.	ECN No.	DESCRIPTION OF CHANGES	DATE	PREPARED
P0		Initial Release	2018-10-19	田静

Contents

No.	Items	Page
1.0	General Description	4
2.0	Absolute Maximum Ratings	6
3.0	Electrical Specifications	7
4.0	Optical Specifications	12
5.0	Reliability Test	15
6.0	Packing Information	16
7.0	Product Label	18
8.0	Handling & Cautions	19
9.0	Appendix	22

1.0 GENERAL DESCRIPTION

1.1 Introduction

DCD-MX101 is a color active matrix TFT LCD FOB using amorphous silicon TFT 's (Thin Film Transistors) as an active switching devices. This module has a 10.1 inch diagonally measured active area with WXGA resolutions (1280 horizontal by 800 vertical pixel array). Each pixel is divided into RED, GREEN, BLUE dots which are arranged in vertical stripe and this module can display 16.7 M colors.

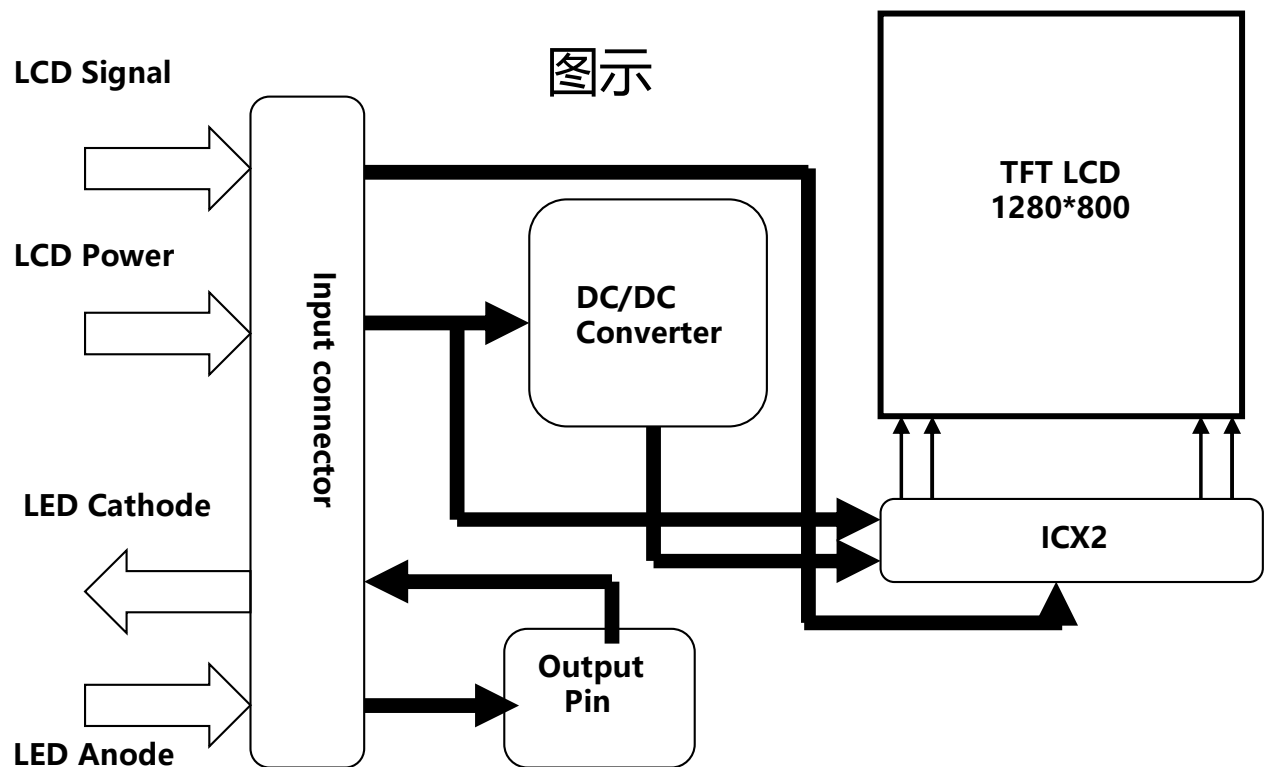

1.2 Features

- LVDS Interface;
- 6bit + Hi-FRC display 16.7M colors
- High contrast ratio and Transmittance

1.3 Application

- G Industrial

1.4 General Specification

The followings are general specifications at the DCD-MX101.

<Table 1. LCD Module Specifications>

Parameter	Specification	Unit	Remarks
Active Area	216.96(H)*135.6(V)	mm	
Number Of Pixels	1280(H)×800(V)	pixels	
Pixel Pitch	0.0565(H)×RGB×0.1695(V)	mm	
Pixel Arrangement	Pixels RGB stripe arrangement		
Display Mode	Normally Black		
Display Colors	16.7M(6bit +Hi-FRC)	colors	
Surface Treatment	HC		
Contrast Ratio	1000:1(typ.)		
Viewing Angle(CR>10)	80/80/80/80(typ.)		
Response Time	35(typ.)/40(max.)	ms	
Color Gamut	50%NTSC		
Power Consumption	Panel: 0.7(Typ.)	watt	待实测
Outline Dimension	228.3(H)*150.05(V)*5.0(typ)	mm	

2.0 ABSOLUTE MAXIMUM RATINGS

The followings are maximum values which, if exceed, may cause faulty operation or damage to the unit.

< Table 2. Absolute Maximum Ratings >

Parameter		Symbol	Min.	Max.	Unit	Remarks
Power Supply	LCD Module	VDD	VSS-0.3	3.6	V	Ta=25 S Note 1&2
Operating Temperature		T _{OP}	-20	+70	°C	Note 3
		T _{SUR}	-20	+70	°C	
Storage Temperature		T _{ST}	-30	+80	°C	
Operating Ambient Humidity		Hop	10	90	%RH	
Storage Humidity		Hst	10	90	%RH	
LED Life Time		LBL	50000		Hrs.	

Note:

1. These range above is maximum value not the actual operating temperature . Actual Operating temperature is no more than 40°C and temperature refers to the LCM surface temperature ; Length of operation: No more than 8 hours per day, and no more than 4 hours of continuous use one time.
2. BOE is not responsible for product problems beyond the use conditions.
3. Temperature and relative humidity range are shown in the figure below. Wet bulb temperature should be 39°C max. and no condensation of water.

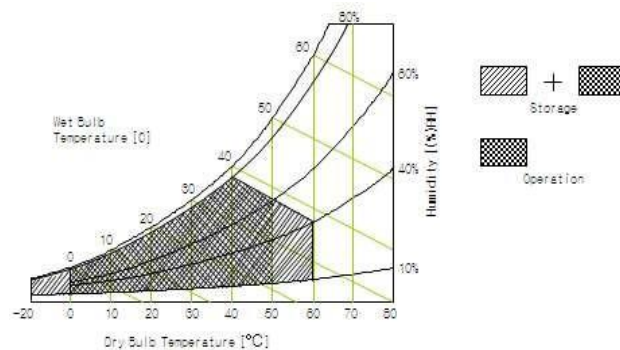

3.0 ELECTRICAL SPECIFICATIONS

3.1 TFT LCD Module

< Table 3. LCD Module Electrical specifications > [Ta =25±2 °C]

Parameter	Symbol	Values			Unit	Notes	
		Min.	Typ.	Max.			
Power Supply Voltage	VDD	3.0	3.3	3.6	V		
	VRP			300	mV	Ripple	
Power Supply Current	IDD	-	212	364	mA	Note 1	
Power Consumption	PLCD	-	0.7	1.2	W		
Rush current	IRUSH	-	-	3.0	A	Note 2	
CMOS Interface	Input Voltage	VIH	2.7		3.3	V	
		VIL	0		0.5	V	
	Output Voltage	VOH	2.7		3.3	V	
		VOL	0		0.5	V	

Notes : 1. The supply voltage is measured and specified at the interface connector of LCM.
 The current draw and power consumption specified is for VDD=3.3V, Frame rate $f_v=60\text{Hz}$ and Clock frequency = 72.4MHz. Test Pattern of power supply current

a) Typ : Mosaic 8 x 6 Pattern(L0/L255)

b) Max : skip subPixel(L255)

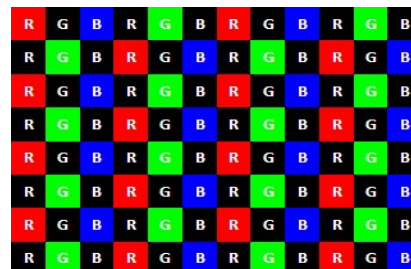
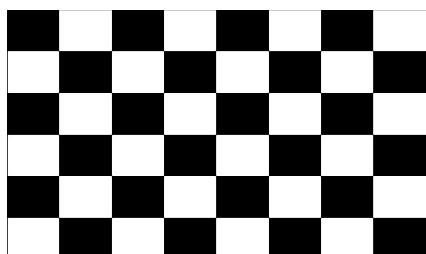

2. The duration of rush current is about 2ms and rising time of Power Input is 1ms(min)

3.2 INPUT TERMINAL PIN ASSIGNMENT

This LCD employs one interface connections, a 40 pin connector is used for the LCD module electronics interface.

3.2.1 Pin assignment for LCD module

Connector : MSAK24025P40G (STM) or equivalent

< Table4. Pin Assignment for LCD Module Connector >

Pin No.	Symbol	Description	I/O
1	NC	Non Connection	-
2	VDDIN	Power supply VDDIN=3.3V (Typ.)	P
3	VDDIN		P
4	VDDIN		P
5	NC	Non Connection	-
6	GND	GROUND	P
7	GND	GROUND	P
8	RIN0-	LVDS Negative data signal (-)	I
9	RIN0+	LVDS Positive data signal (+)	I
10	GND	GROUND	P
11	RIN1-	LVDS Negative data signal (-)	I
12	RIN1+	LVDS Positive data signal (+)	I
13	GND	GROUND	P
14	RIN2-	LVDS Negative data signal (-)	I
15	RIN2+	LVDS Positive data signal (+)	I
16	GND	GROUND	P
17	LVDS_CLK-	LVDS Negative CLK signal (-)	I
18	LVDS_CLK+	LVDS Positive CLK signal (+)	I
19	GND	GROUND	P
20	RIN3-	LVDS Negative data signal (-)	I

Pin No.	Symbol	Description	I/O
21	RIN3+	LVDS Positive data signal (+)	I
22	GND	GROUND	P
23	NC	Non Connection	-
24	NC	Non Connection	-
25	GND	GROUND	P
26	NC	Non Connection	-
27	NC	Non Connection	-
28	GND	GROUND	P
29	NC	Non Connection	-
30	NC	Non Connection	-
31	LED-	LED Cathode	O
32	LED-		O
33	LED-		O
34	NC	Non Connection	-
35	NC	Non Connection	-
36	NC	Non Connection	-
37	NC	Non Connection	-
38	LED+	LED Anode	P
39	LED+		P
40	LED+		P

3.3 Interface timing Parameter

< Table5. LVDS Timing Parameter >

Parameter	Symbol	Value			Unit
		Min.	Typ.	Max.	
DCLK Frequency	Fdclk	66.3	72.4	78.9	MHz
Horizontal display area	Thd	1280			pixel
HSYNC period time	Th	1380	1440	1500	pixel
HSYNC blanking	thbp+ thfp	100	160	220	pixel
Vertical display area	Tvd	800			H
Frequency	fV	55	60	65	Hz
VSYNC period time	Tv	824	838	872	H
VSYNC blanking	Tvbp+ Tvfp	24	38	72	H

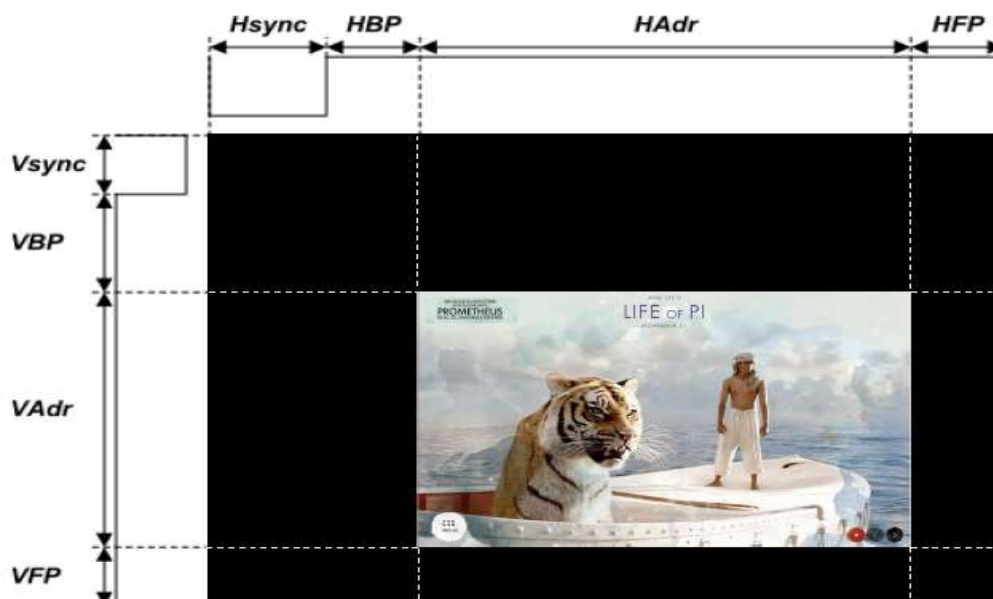

3.4 Power Sequence

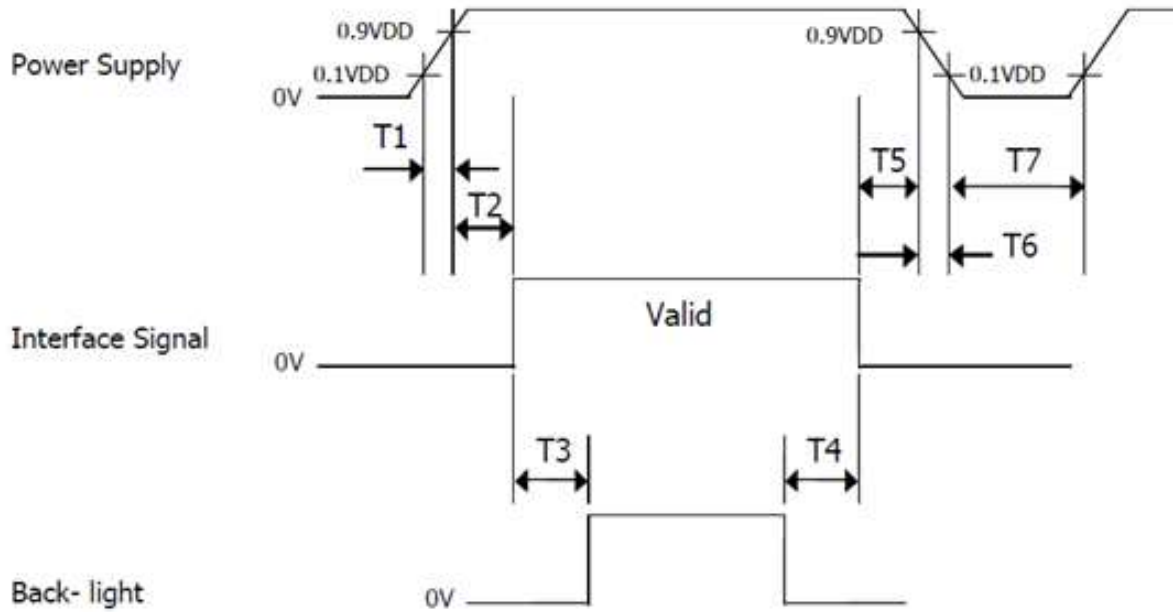

< Table6. Sequence Table >

Parameter	Values			Units
	Min	Typ	Max	
T1	0	-	10	ms
T2	0	-	50	ms
T3	200	-	-	ms
T4	500	-	-	ms
T5	0	-	50	ms
T6	0	-	10	ms
T7	500	-	-	ms

4.0 OPTICAL SPECIFICATIONS

4.1 Overview

The test of optical specifications shall be measured in a dark room (ambient luminance ≤ 1 lux and temperature = $25 \pm 2^\circ\text{C}$) with the equipment of Luminance meter system (Gonio meter system and TOPCON BM-5) and test unit shall be located at an approximate distance 50cm from the LCD surface at a viewing angle of θ and Φ equal to 0° . We refer to $\theta\emptyset=0$ ($=\theta_3$) as the 3 o' clock direction (the "right"), $\theta\emptyset=90$ ($=\theta_{12}$) as the 12 O' clock direction ("upward"), $\theta\emptyset=180$ ($=\theta_9$) as the 9 O' clock direction ("left") and $\theta\emptyset=270$ ($=\theta_6$) as the 6 O' clock direction ("bottom"). While scanning θ and/or \emptyset , the center of the measuring spot on the Display surface shall stay fixed.

4.2 Optical Specifications < Table7. Optical Table >

Item	Symbol	Condition	Min	Typ.	Max	Unit	Note
Viewing Angle	θ_L	$Cr \geq 10$	70	80	--	deg	Note 1
	θ_R		70	80	--		
	ψ_T		70	80	--		
	ψ_B		70	80	--		
Contrast Ratio	Cr	$\theta=0^\circ$	--	1000		-	Note 2
Response Time	Tr+Tf	FF= 0°	--	35	40	ms	Note 3
Color Coordinate of CIE1931	Rx	$\theta=0^\circ$		--		-	Note 4
	Ry			--			
	Gx			--			
	Gy			--			
	Bx			--			
	By			--			
	Wx			--			
	Wy			--			
NTSC Ratio	NTSC	CIE1931	45	50	--	%	Note 5
Gamma	-		1.9	2.2	2.5		Note 6
Polarization Direction of Front Polarizer	PdF	-		0		deg	Absorption axis Note 7
Polarization Direction of Rear Polarizer	PdR			90		deg	

Note 1: The definition of Viewing Angle

Refer to the graph below marked by θ and ϕ .

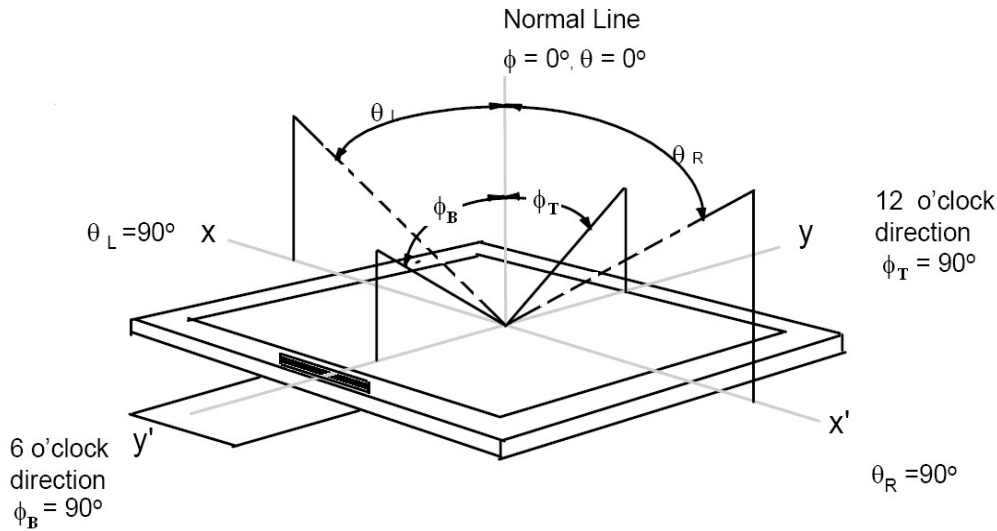

Note 2: The definition of Contrast Ratio

$$\text{Contrast Ratio (CR)} = \frac{\text{Luminance When LCD is at "White" state}}{\text{Luminance When LCD is at "Black" state}}$$

(Contrast Ratio is measured in optimum common electrode voltage)

Note 3: Definition of Response time. (Test LCD using RD80S or similar equipments):

The output sign also photo detector are measured when the input sign also are changed from "black" to "white" (Voltage falling time) and from "white" to "black" (Voltage rising time), respectively. The response time is defined as the time interval between the 10% and 90% of amplitudes. Refer to figures below.

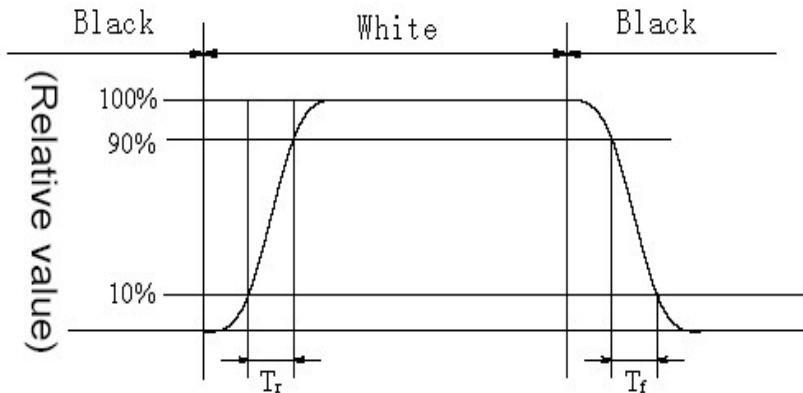

Note 4: Color Coordinates of CIE 1931

The test condition is at ILED=20mA and measured on the surface of LCD module at 25°C.

Measurement equipment: CS2000 or similar equipments

The Color Coordinate (CIE 1931) is the measurement of the center of the display shown in below figure.

Note 5: Definition of Color of CIE Coordinate and NTSC Ratio.

$$S = \frac{\text{area of RGB triangle}}{\text{area of NTSC triangle}} \times 100\%$$

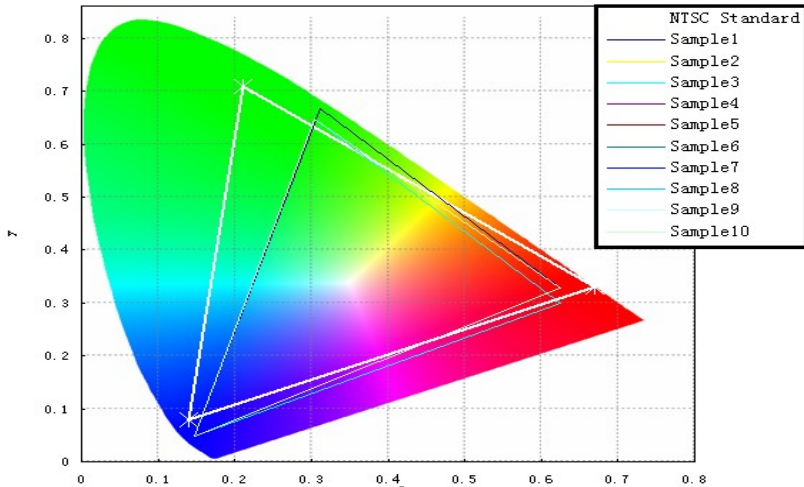

Note 6: gamma curve control

- For gamma curve control, HUAWEI's request as below:
- 1, the whole curve's tolerance must control within +/-0.3, HUAWEI will test the gray scale below: 0, 8, 16, 25, 33, 41, 49, 58, 66, 74, 82, 90, 99, 107, 115, 123, 132, 140, 148, 156, 165, 173, 181, 189, 197, 206, 214, 222, 230, 239, 247, 255

Note 7: Polarization Direction Definition

- Viewing direction is normal user viewing direction which is vertical to the display surface
- The polarizer which is closer to viewer is defined as Front Polarizer
- The polarizer which is on the rear side of viewer is defined as Rear Polarizer
- The X axis is defined as parallel line to top & bottom sidelines of the Active Area
- PdF which is marked in blue arrow is polarization degree of Front polarizer
- PdR which is marked in red arrow is polarization degree of Back polarizer
- The polarization degree parameter must be indicated in range of 0deg to 180deg according to above definition

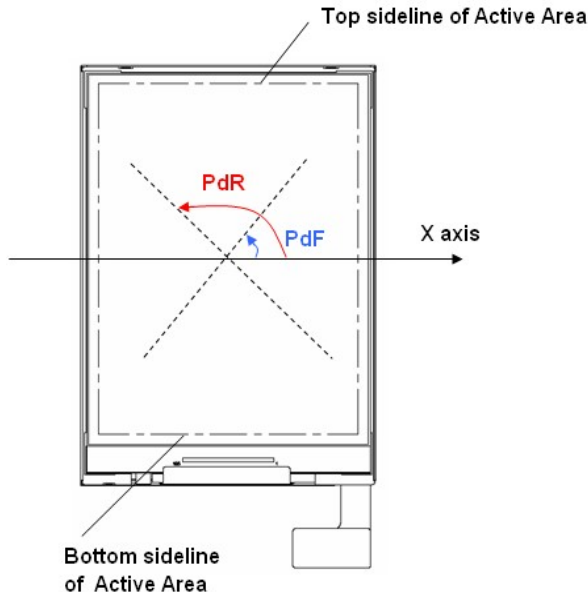

5.0 RELIABILITY TEST

The Reliability test items and its conditions are shown in below.

<Table 8. Reliability Test Parameters >

No	Test Items	Conditions
1	High temperature storage test	80°C 240hr
2	Low temperature storage test	-30°C 240hr
3	Low temperature operation test	-20°C 240hr
4	High temperature operation test	70°C 240hr
5	High temperature & high humidity (operation test)	60°C 90%RH 240hr
6	Thermal Shock Test	-40°C~80°C 1hr/cycle 100cycle
7		
8		
9		
10		
...		

8.0 Handling & Cautions

8.1 Mounting Method

- The panel of the LCD consists of two thin glasses with polarizers which easily get damaged. So extreme care should be taken when handling the LCD.
- Excessive stress or pressure on the glass of the LCD should be avoided. Care must be taken to insure that no torsional or compressive forces are applied to the LCD unit when it is mounted.
- If the customer's set presses the main parts of the LCD, the LCD may show the abnormal display. But this phenomenon does not mean the malfunction of the LCD and should be pressed by the way of mutual agreement.
- To determine the optimum mounting angle, refer to the viewing angle range in the specification for each model.
- Mount a LCD module with the specified mounting parts.

8.2 Caution of LCD Handling and Cleaning

- Since the LCD is made of glass, do not apply strong mechanical impact or static load onto it. Handling with care since shock, vibration, and careless handling may seriously affect the product. If it falls from a high place or receives a strong shock, the glass may be broken.
- The polarizers on the surface of panel are made from organic substances. Be very careful for chemicals not to touch the polarizers or it leads the polarizers to be deteriorated.
- If the use of a chemical is unavoidable, use soft cloth with solvent (recommended below) to clean the LCD 's surface with wipe lightly.
-IPA(Isopropyl Alcohol), Ethyl Alcohol, Trichlorotrifluoroethane
- Do not wipe the LCD's surface with dry or hard materials that will damage the polarizers and others. Do not use the following solvent.
-Water, Ketone, Aromatics
- It is recommended that the LCD be handled with soft gloves during assembly, etc. The polarizers on the LCD's surface are vulnerable to scratch and thus to be damaged by sharp particles.
- Do not drop water or any chemicals onto the LCD's surface.
- A protective film is supplied on the LCD and should be left in place until the LCD is required for operation.
- The ITO pad area needs special careful caution because it could be easily corroded. Do not contact the ITO pad area with HCFC, Soldering flux, Chlorine, Sulfur, saliva or fingerprint. To prevent the ITO corrosion, customers are recommended that the ITO area would be covered by UV or silicon.

8.3 Caution Against Static Charge

- The LCD modules use C-MOS LSI drivers, so customers are recommended that any unused input terminal would be connected to Vdd or Vss, do not input any signals before power is turn on, and ground you body, work/assembly area, assembly equipments to protect against static electricity.
- Remove the protective film slowly, keeping the removing direction approximate 30-degree not vertical from panel surface, If possible, under ESD control device like ion blower, and the humidity of working room should be kept over 50%RH to reduce the risk of static charge.
- Avoid the use work clothing made of synthetic fibers. We recommend cotton clothing or other conductivity-treated fibers.
- In handling the LCD, wear non-charged material gloves. And the conducting wrist to the earth and the conducting shoes to the earth are necessary.

8.4 Caution For operation

- It is indispensable to drive the LCD within the specified voltage limit since the higher Voltage than the limit causes the shorter LCD's life. An electro-chemical reaction due to DC causes undesirable deterioration of the LCD so that the use of DC drive should avoid.
- Do not connect or disconnect the LCD to or from the system when power is on.
- Never use the LCD under abnormal conditions of high temperature and high humidity.
- When expose to drastic fluctuation of temperature (hot to cold or cold to hot) ,the LCD may be affected; Specifically, drastic temperature fluctuation from cold to hot ,produces dew on the LCD's surface which may affect the operation of the polarizer and the LCD.
- Response time will be extremely delayed at lower temperature than the operating temperature range and on the other hand at higher temperature LCD may turn black at temperature above its operational range. However those phenomena do not mean malfunction or out of order with the LCD. The LCD will revert to normal operation once the temperature returns to the recommended temperature range for normal operation.
- Do not display the fixed pattern for a long time because it may develop image sticking due to the LCD structure. If the screen is displayed with fixed pattern, use a screen saver.

8.5 Packaging

- Modules use LCD element, and must be treated as such.
 - Avoid intense shock and falls from a height.
 - To prevent modules from degradation, do not operate or store them exposed directly to sunshine or high temperature/humidity for long periods.

8.6 Storage

- A slight dew depositing on terminals is a cause for electro-chemical reaction resulting in terminal open circuit. Relative humidity of the environment should therefore be kept below 60%RH.
- Original protective film should be used on LCD's surface (polarizer). Adhesive type protective film should be avoided, because it may change color and/or properties of the polarizers.
- Do not store the LCD near organic solvents or corrosive gasses.
- Keep the LCD safe from vibration, shock and pressure.
- Black or white air-bubbles may be produced if the LCD is stored for long time in the lower temperature or mechanical shocks are applied onto the LCD.
- In the case of storing for a long period of time for the purpose or replacement use, the following ways are recommended.
 - Store in a polyethylene bag with sealed so as not to enter fresh air outside in it.
 - Store in a dark place where neither exposure to direct sunlight nor light is.
 - Keep temperature in the specified storage temperature range.
 - Store with no touch on polarizer surface by the anything else. If possible, store the LCD in the packaging situation LCD when it was delivered.

8.7 Safety

- For the crash damaged or unnecessary LCD, it is recommended to wash off liquid crystal by either of solvents such as acetone and ethanol and should be burned up later.
- In the case the LCD is broken, watch out whether liquid crystal leaks out or not. If your hands touch the liquid crystal, wash your hands cleanly with water and soap as soon as possible.
- If you should swallow the liquid crystal, first, wash your mouth thoroughly with water, then drink a lot of water and induce vomiting, and then, consult a physician.
- If the liquid crystal should get in your eyes, flush your eyes with running water for at least fifteen minutes.
- If the liquid crystal touches your skin or clothes, remove it and wash the affected part of your skin or clothes with soap and running water.

1	2	3	4	5	6	7	8
demmel products gmbh				Customer Code.:		SPECIFICATION OF BACKLIGHT	
Date: 2022.05.27	Page: 1/1		THE THIRD ANGLE	CUSTOMER'S P/N:	DCD-MX101	EDITION: 01	
						FX S P/N: (include wrapper)	
						Approval (核准)	
						Check (检查)	
						Design (设计)	
						Laughing	

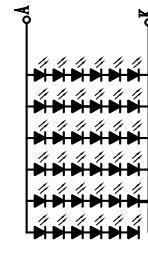
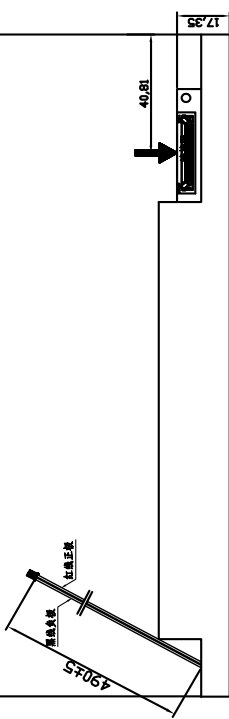
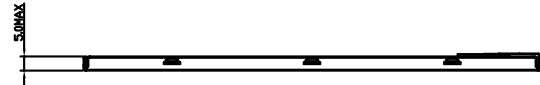
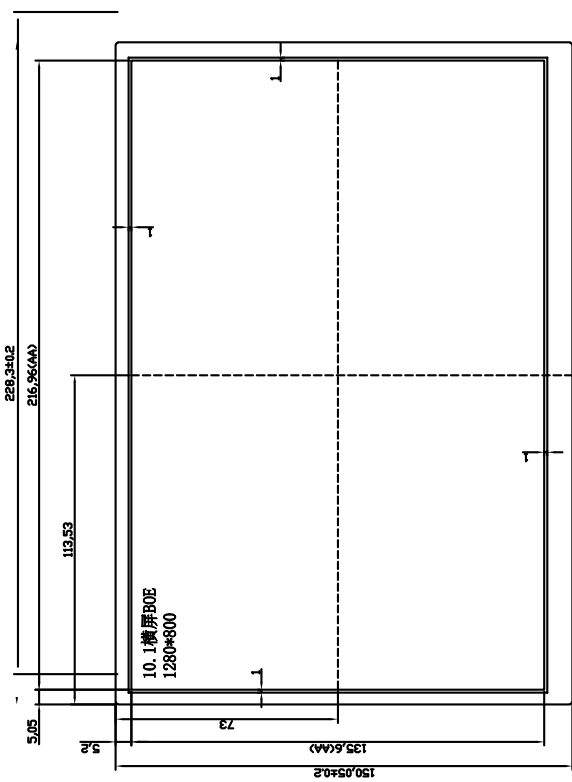

- Notes:
1. Unit:mm.
 2. Do not scale drawing.
 3. All radii without dimension R0.2.
 4. Δ Modification Mark.
 5. draft angle: 1°
 6. Backlight luminance : 1000 cd/ m²
 7. Luminance uniformity: 75%(min) (min/max*100%)
 8. UnSpecified Tolerance is ± 0.2
 9. Operation conditions :If= 280-360mA, Vf=16. 8-19. 8V (MAX)
Color coordinate:X=0.27-0.35, Y=0.27-0.35
 10. All materials comply with RoHS
 11. The measured value of luminance and color coordinate bases FX's BM-7
 - 12: Check item: 1, 9

11	FPC (软性线路板)	1
10	Double sided stick (双面胶)	2
9	HOUSING (塑胶框)	1
8	PCB(印制电路板)	1
7	Wire(导线)	1
6	LED (发光二极管)	36
5	BEF(偏光片)	2
4	Diffuser film(扩散片)	1
3	Light guide plate (导光板)	1
2	Reflector film(反射膜)	1
1	Rear iron frame (不锈钢框)	1
	TITLE	Quantity

REV	DATE	DESCRIPTION (修改内容)	REVISER	NO.

Approval Date: 确认日期

Approve by: 确认

1	2	3	4	5	6	7	8
Customer:				Approval Date:		Approve by:	
客户		确认日期		确认			